



ClickOn Bus Network Installation Guide

Revision 2.0, May 2010

Copyright in the whole and every part of this document belongs to ClickOn Technology (Pty) Ltd.. It may not be used, sold, transferred, copied or reproduced in whole or in part in any manner or form except with the prior written consent of ClickOn Technology, or as permitted by applicable law. Any copies or reproduction of this document/drawing (in whole or in part) made by any method must include a copy of this legend.

This document is supplied without liability for errors or omissions

ClickOn ® is a registered trademark of ClickOn Technology (Pty) Ltd

1. Precautions

Always observe the local safety and wiring regulations regarding the electrical installation of the Bus network.

Always turn off the supply to the Bus Network and Bus mains wiring before making any changes to the network.

Test all newly crimped cables with a LAN network cable tester before plugging the cables onto the Bus network. Incorrectly crimped cables may cause damage to the Bus Devices.

Keep a safe isolation distance of minimum 50mm (2 inches) or as determined by local regulations between mains wiring and Bus network cables. Never run Bus cables via the same conduits as mains cabling.

Do not install any Bus devices in areas of high humidity.

Most Bus devices have been designed to operate over an ambient temperature range between 0 °C and 40 °C (32 °F to 104 °F). Allow for sufficient ventilation and cooling especially when installing high power devices such as Bus Dimmer units.

2. Bus Network Wiring

The Clickon Bus Network system uses a standard CAT5 UTP (Category 5 Unshielded Twisted pair (4 pairs), stranded or single core) cable as its network communications cable.

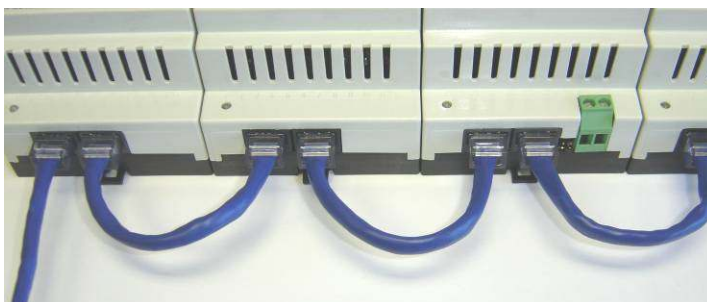

All connections between Bus devices are made using CAT5 cable and RJ45 connector plugs. Each din rail mounted Bus device is supplied with a prewired 130mm (5inch) jumper cable for connection to an adjacent device. A 350mm (14inch) prewired cable is available for connection between din rail rows. Cables to the rest of the Bus network (wallswitches) need to be crimped with the appropriate crimping tool according to the following diagram:

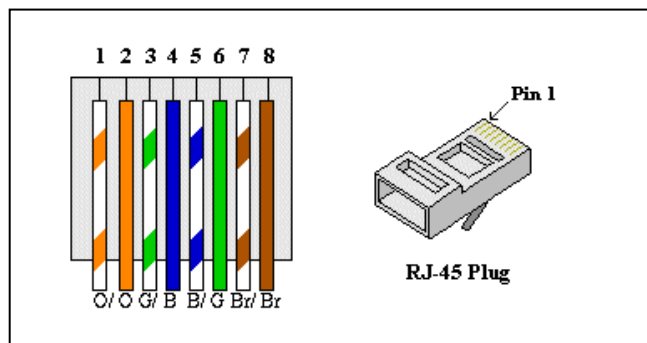
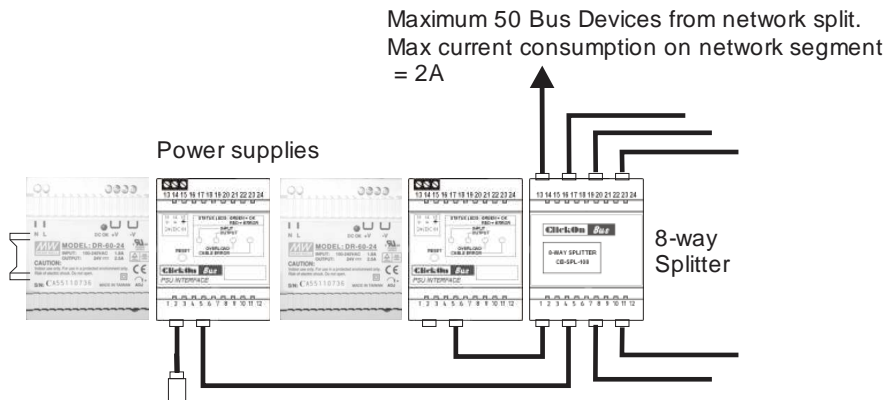

Figure 1. Network cable colour coding and RJ45 plug pinout

A free topology architecture is possible through the use of splitter devices. Two types of splitter devices are available: 3-way (CB-SPL-10) and 8-way (CB-SPL-108). A Splitter can be inserted anywhere on the bus network.

The total number of devices on a single network split from the power supplies (split closest to the power supply) must not exceed 50 devices.

The total current consumption of devices on a single network split from the power supplies must not exceed 2A (see *Bus Network Power Supply*)



The total cable length on a single bus network may not exceed 1000m or 3280feet.

The total number of devices on a single bus network may not exceed 256.

3. Bus Network Power Supply

Power to the Bus Network is supplied via one or more 24VDC 2.5A power supply units (DR-60-24)

Each Power Supply Unit must be connected to the network via a separate Power Supply Interface unit (CB-PSI-12).

Each power supply interface can supply up to 2A to the network.

More than one power supply and power supply interface combination can be used if the total network current consumption exceeds 2A.

To obtain the total current requirement of a Bus Network, add up the individual current consumptions of all devices on the network (see table 1).

PART NUMBER	DESCRIPTION	CONSUMPTION
CB-DIM-10	Dimmer 400W	0.02A
CB-DIM-20	Dimmer 900W	0.02A
CB-POW-11	Power Switch 3000W	0.05A
CB-REL-104	4CH Relay module	0.10A
CB-WBS-101	1 Button Wallswitch	0.03A
CB-WBS-102	2 Button Wallswitch	0.03A
CB-WBS-103	3 Button Wallswitch	0.03A
CB-WBS-106	6 Button Wallswitch	0.03A
CB-WSL8-103RG	3 Button Wallswitch Lumen8	0.05A
CB-WSL8-106RG	6 Button Wallswitch Lumen8	0.08A
CB-RFT-10	RF Transceiver	0.05A
CB-SWI-106	6CH Switch Interface	0.02A
CB-SWI-206	6CH Switch Interface with LED outputs (excluding auxiliary 12VDC 100mA Output)	0.04A
CB-10V-104	4CH 0-10V Controller	0.03A
CB-232-10	USB Interface	0.05A
CB-PSI-12	Power Supply Interface	0.05A
CB-RCI-10	Remote Commander Interface with Timer Only Remote Commander	0.15A
CB-RCI-10	Remote Commander Interface with GSM Remote Commander	0.25A
CB-DAL-10	DALI Gateway	0.08A
CB-IFT-10	Interface Translator	0.10A

Table 1. Device Current Consumptions.

The power supply(s) must be installed at the point where most devices are located (usually the distribution box) to avoid excessive voltage drops over long cables. It is recommended that all power supplies be installed in a single location together with one or more 8-way splitters.

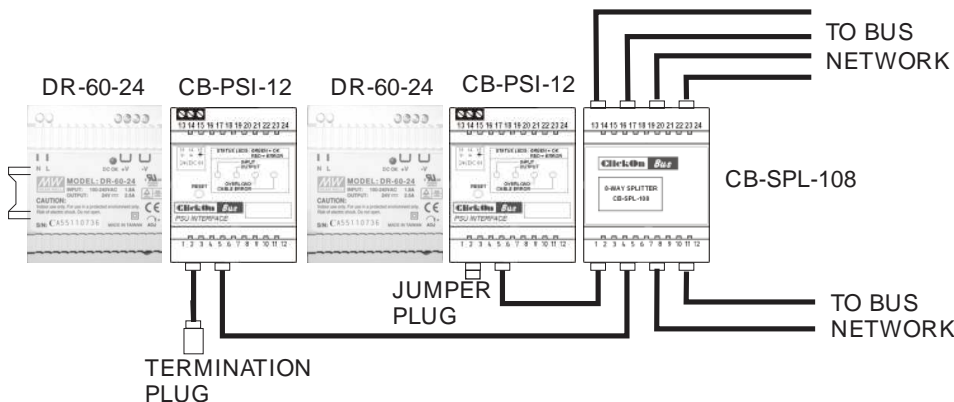

The supply voltage at any point on the network must not be lower than 15VDC. The voltage at any jumper plug (this will always represent the furthest point from the power supply on a specific network split) can be measured by constructing a simple breakout cable:

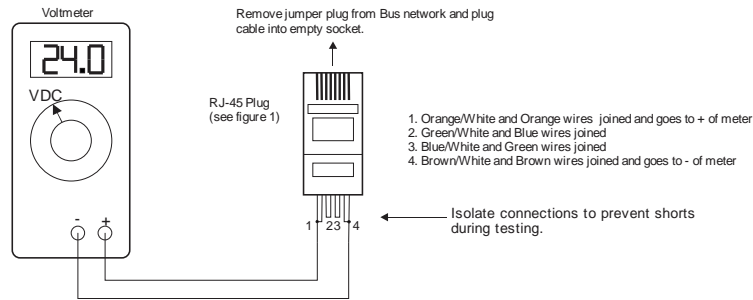

If a voltage lower than 15V is measured, the number of devices on that network split needs to be reduced (see *Bus Network Wiring*).

4. Network Termination and Jumper Plugs

Each network must contain ONE and only one network Termination Plug (CB-TPL-10). It is recommended that the Termination Plug always be installed at the first power supply interface for ease of maintenance.

No open ends or open connectors are allowed on the network (including any open ports on a splitter device). All open ends or open connectors (usually the last device on a network split) must be terminated with a Network Jumper Plug (CB-JPL-10)

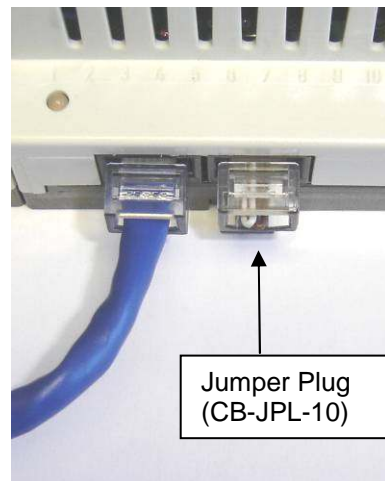
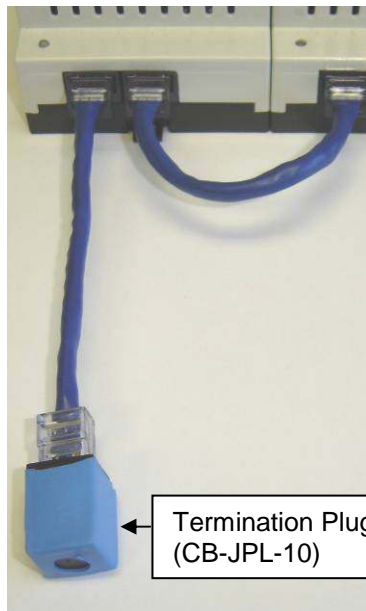

5. Typical Application

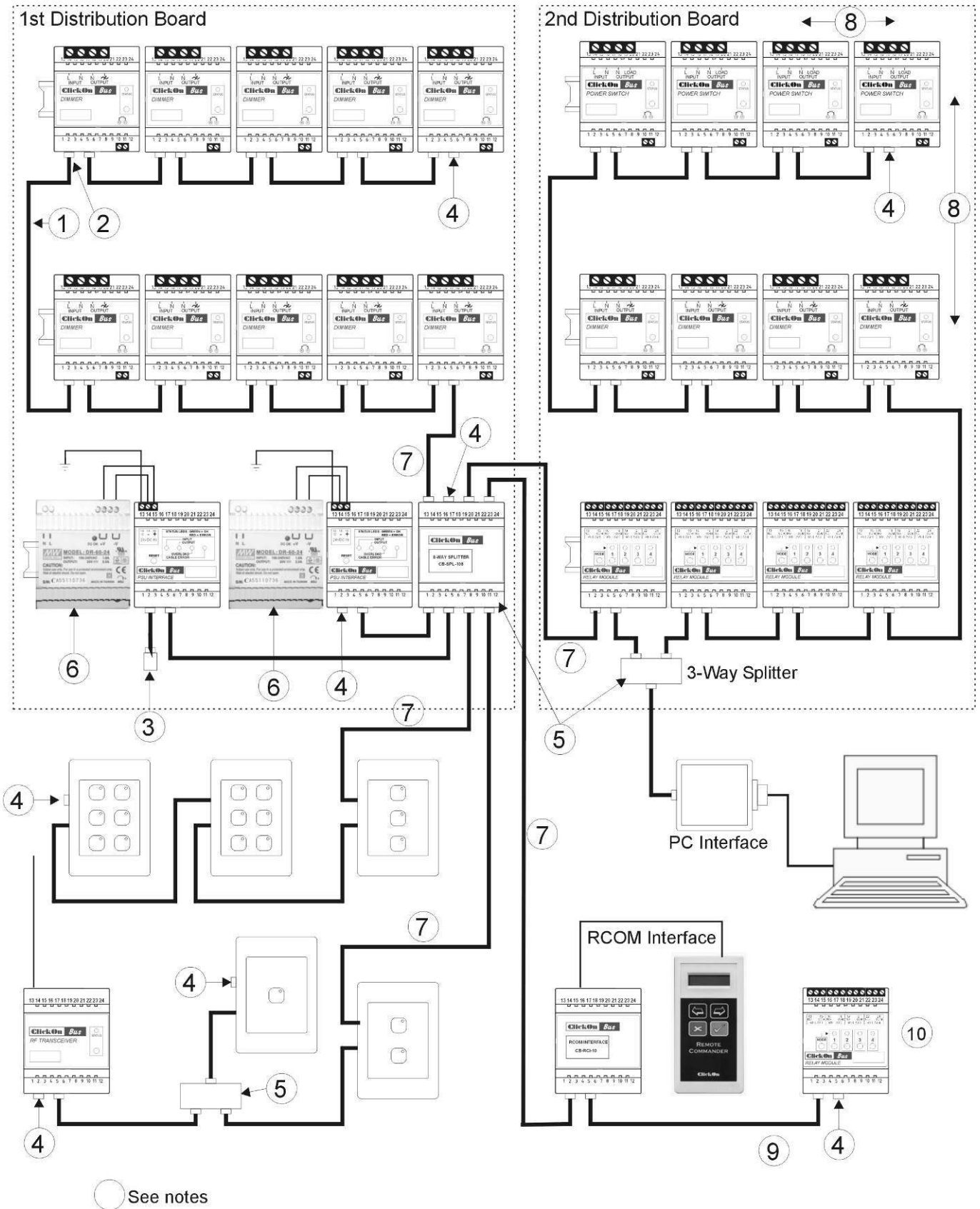

Notes

1. **Network cable**
 - a. CAT5 UTP (Category 5 Unshielded Twisted pair (4 pairs), stranded or single core)
2. **Crimp Connectors**
 - a. All cable ends must be terminated with RJ45 plugs (see figure 1)
3. **Network Termination Plug**
 - a. Each network must have ONE and only one network Termination Plug (CB-TPL-10).
 - b. It is recommended that the Termination Plug always be installed at the power supply interface.
4. **Jumpers**
 - a. No open ends or open connectors are allowed on the network.
 - b. All open ends or open connectors must be terminated with a Network Jumper Plug (CB-JPL-10)
5. **Splitters**
 - a. Where a T-junction or network split is required, a Splitter box must be used (CB-SPL-10 or CB-SPL-108)
 - b. A Splitter can be inserted anywhere on the network
6. **Power Supply**
 - a. Each Power Supply Unit must be connected to the network via a separate Power Supply Interface unit (CB-PSI-12)
 - b. Each power supply can supply up to 2A to the network
 - c. More than one power supply can be used if the total network current consumption exceeds 2A
 - d. To obtain the total current requirement, add up the individual current consumptions of all devices on the network (see table 1)
 - e. The power supply(s) must be installed at the point where most devices are located (usually the distribution board) to avoid excessive voltage drops over long cables
 - f. The supply voltage at any point on the cable (pin 1 and 8) must be between 15 and 24VDC.
7. **Supply Distribution**
 - a. The total number of devices on a single network split from the power supplies must not exceed 50 devices
 - b. The total current consumption of devices on a single network split from the power supplies must not exceed 2A (see table 1)
8. **Device Placement and Isolation**
 - a. The ClickOn Bus units have been designed to operate over an ambient temperature range between 0 °C and 40 °C at the rated maximum load capacities. Sufficient spacing and airflow between devices should be allowed for in the distribution board. The minimum recommended horizontal spacing between dimmer devices is one din rail module width (17mm or 2/3inches).
 - b. All network connections and cabling are low voltage and optically isolated from the mains supply voltage and must thus be kept away from any mains wiring
 - c. Sufficient spacing must be allowed for this between consecutive din rails in the distribution board (minimum recommended spacing between din rail centers = 150mm or 6inches)
 - d. Do NOT route any network cables via the same conduits as mains wiring
9. **Maximum Cable Length**
 - a. The total cable length on a single bus network may not exceed 1000m (3280feet)
10. **Maximum Number of Devices**
 - a. The total number of devices on a single bus network may not exceed 256

6. Troubleshooting a Bus Network installation

Do a List Devices with the CLBUS installation software. The number of devices detected should always equal those in the actual installation.

Possible causes of an unreliable network include:

- Missing Termination Plug: Check that the network contains one Termination plug.
- Missing Jumper Plugs: Check that there are no open network plugs on the Bus network.
- Cable error: Check all network cabling and crimp connections.
- Maximum cable length exceeded.
- Maximum current consumption or device count on a network split exceeded (*see Bus Network Power Supply*)
- Faulty device.

Finding a faulty device on the network

- Faulty devices or cables are best found through a process of elimination.
- Try isolating parts of the network by replacing a specific network section with a jumper plug at the splitter device until the faulty network section is found.

Error indication on a Bus Power Supply Interface (CB-PSI-12)

- Because of the nature of a Bus Network, certain fault conditions may not be detected by the Power Supply Interface. It is thus possible for a Power Supply Interface to indicate no errors on a faulty network.
- However, an error condition on the Power Supply Interface should always be treated a true network fault.